

NOVA RADIO LABS, LLC (C) 2024

NOVADUINO (tm)
Development Board

Display 2.4 Inch TFT LCD Mother Board
(fits: Feather*/Thing Plus**)

NRL1000014 RevC 10-14-2024
Production Release

* from Adafruit
** from SparkFun

NOVADUINO(tm) Display 2.4 inch
Nova Radio Labs, LLC (c)2024
Engineer: R. Durrant

TITLE: Novaduino_Display_2p4_MB_NRL1000014-revC

Document Number:
NRL1000014

REV:
C

Date: 7/28/2025 11:09 AM

Sheet: 1/5

PROCESSOR

SpakFun/Thing Plus or Adafruit/Feather or Equivalent

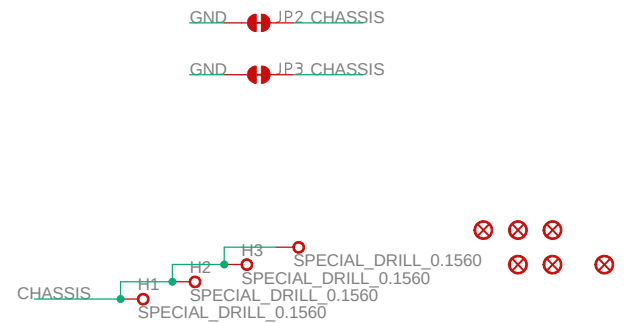
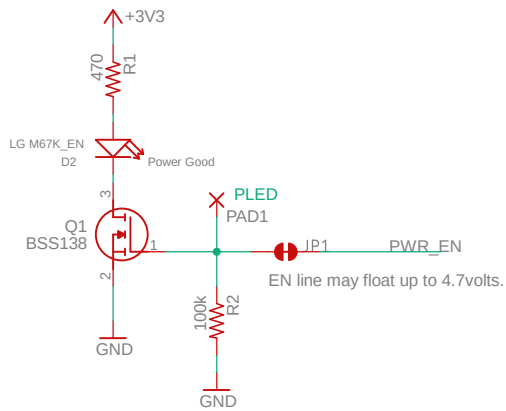
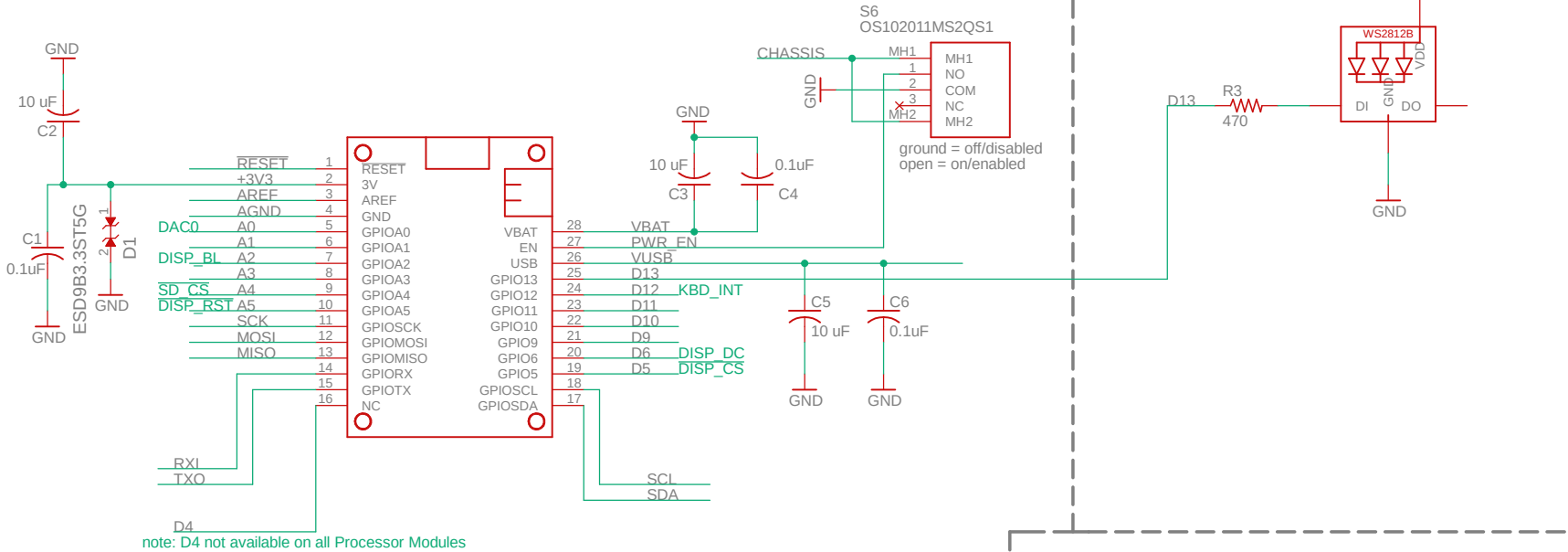

NOVADUINO(tm) Display 2.4 inch
Nova Radio Labs, LLC (c)2024
Engineer: R. Durrant

TITLE: Novaduino_Display_2p4_MB_NRL1000014-revC	
Document Number: NRL1000014	REV: C
Date: 7/28/2025 11:09 AM	Sheet: 2/5

Key and Encoder Processor

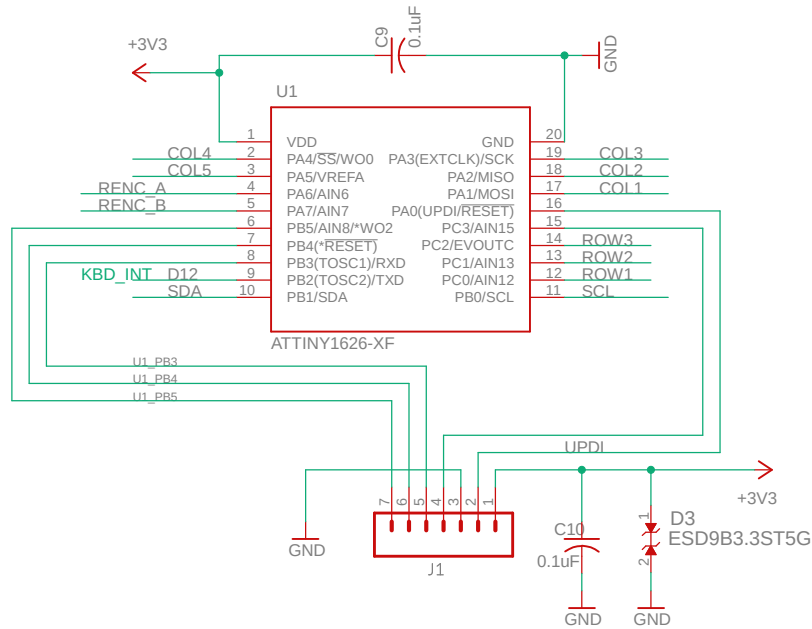

TACT SWITCHES

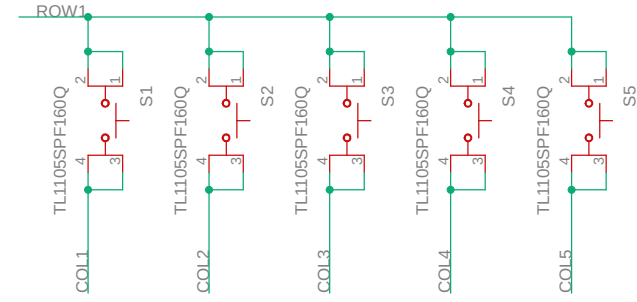

Rotary Encoder

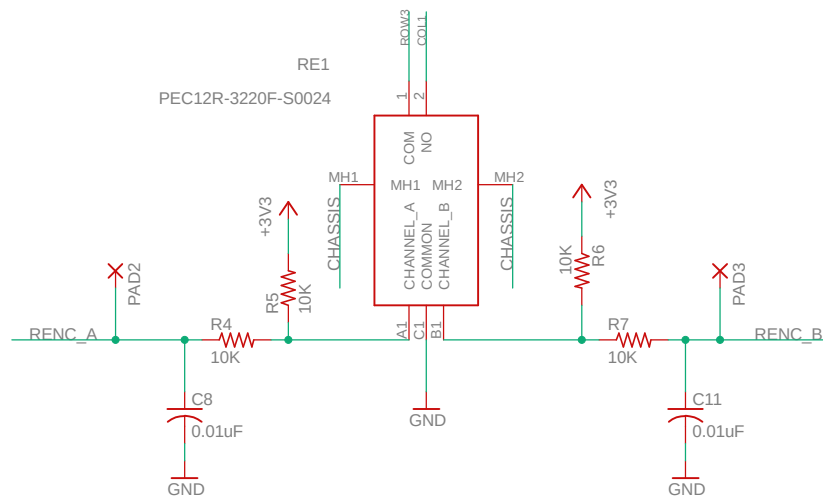

Nav Switch

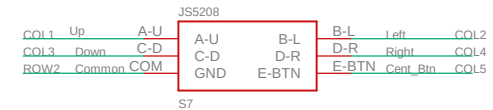

NOVADUINO(tm) Display 2.4 inch
 Nova Radio Labs, LLC (c)2024
 Engineer: R. Durrant

TITLE: Novaduino_Display_2p4_MB_NRL1000014-revC

Document Number:
 NRL1000014

REV:
 C

Date: 7/28/2025 11:09 AM

Sheet: 3/5

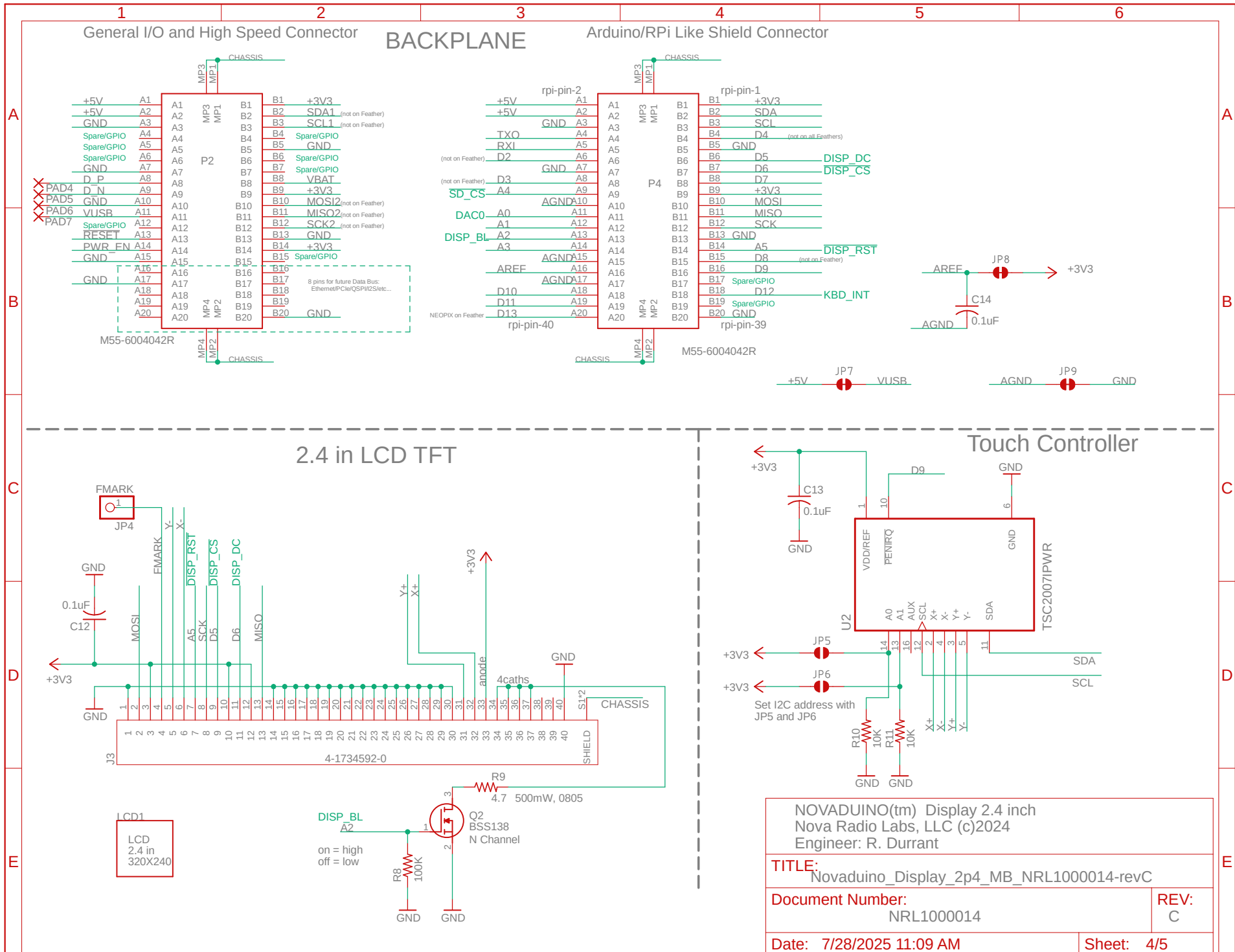

1 General I/O and High Speed Connector

BACKPLANE

2 3 4 Arduino/RPi Like Shield Connector

5 6

A

B

C

D

E

A

B

C

D

E

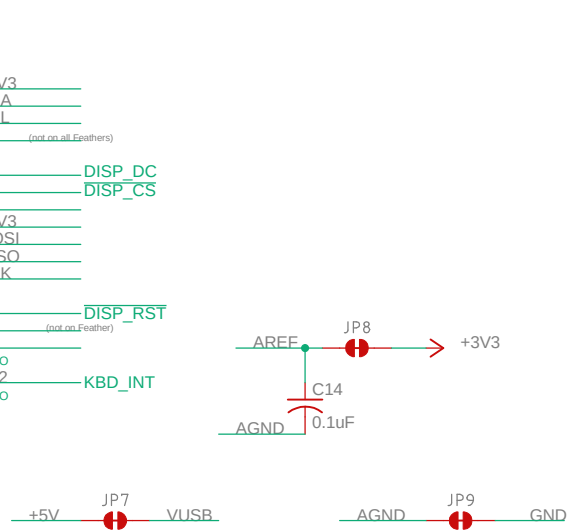
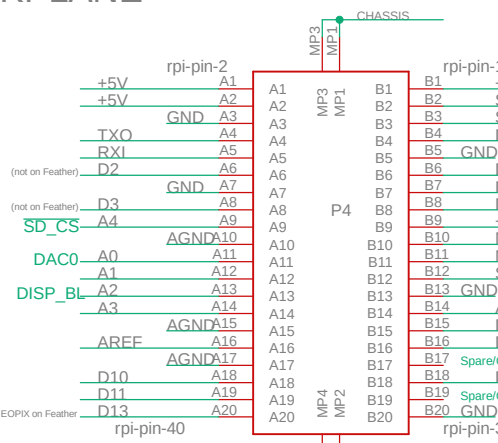
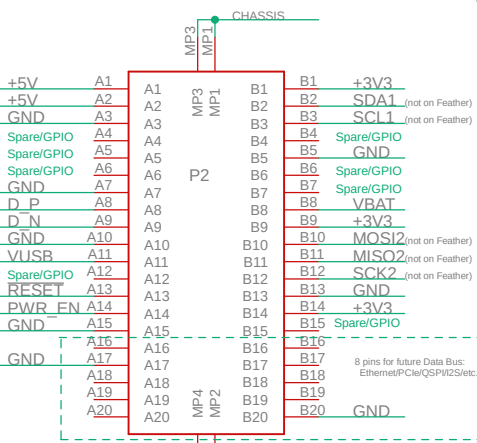

2.4 in LCD TFT

Touch Controller

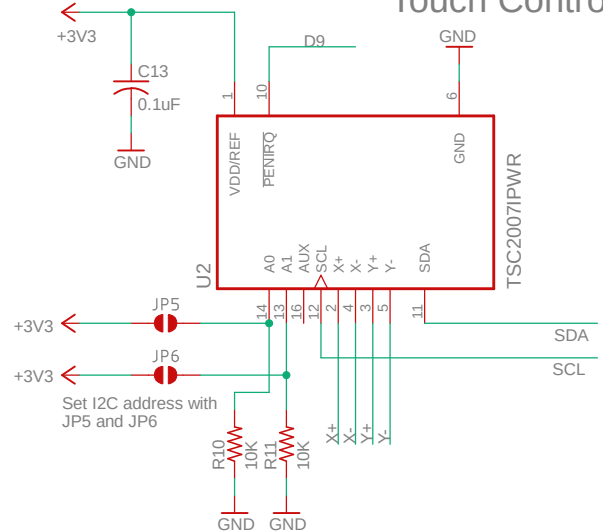
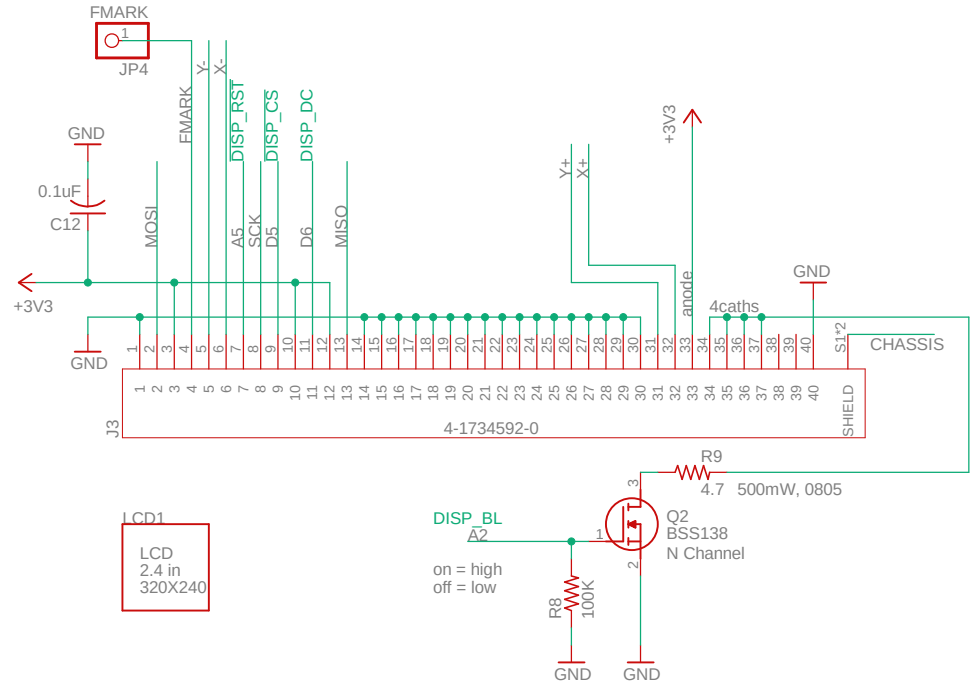

NOVADUINO(tm) Display 2.4 inch Nova Radio Labs, LLC (c)2024 Engineer: R. Durrant	
TITLE: Novaduino_Display_2p4_MB_NRL1000014-revC	
Document Number: NRL1000014	REV: C
Date: 7/28/2025 11:09 AM	Sheet: 4/5

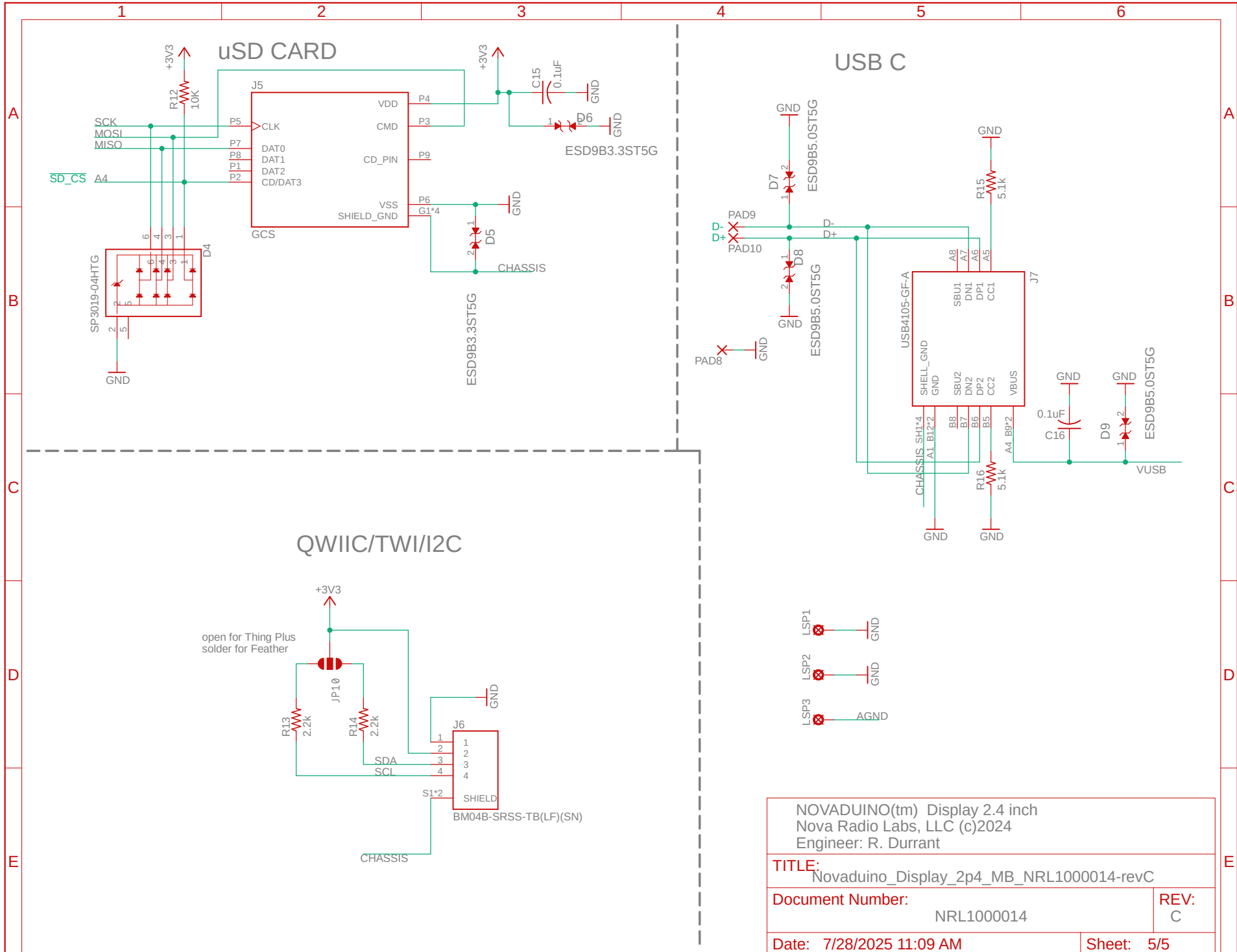

NOVADUINO(tm) Display 2.4 inch
 Nova Radio Labs, LLC (c)2024
 Engineer: R. Durrant

TITLE: Novaduino_Display_2p4_MB_NRL1000014-revC

Document Number: NRL1000014 REV: C

Date: 7/28/2025 11:09 AM Sheet: 5/5